

# BODY ARMOR

BY TOLAR MFG. CO., INC.

## Body Armor Swing-Arm Tire Can Carrier

PART NUMBER 5292

*Body Armor PN 5292 is Compatible with ONLY Body Armor bumpers PN CJ-2993, JK-2393, TJ-2993 & YJ-2993*



*5292 Shown Mounted on a TJ-2993 Gas Cans and Hi-Lift Jack are available at your local Body Armor Dealer*



**X**trême trailgear  
for the serious  
offroader!

[www.bodyarmor4x4.com](http://www.bodyarmor4x4.com)

Body Armor by Tolar Mfg.  
258 Mariah Circle  
Corona, CA 92879 PH: 951-808-0750 FAX: 951-808-0041  
5292 v.5/2008

## 5292 Installation Instructions

**\*\*NOTE: The 5292 swing-Arm is designed to work ONLY with Body Armor bumpers (PN CJ-2993, JK-2393, TJ-2993 & YJ-2993)**

**\*\* NOTE: Hardware Includes: Hinge pin QTY 1, Set screw QTY 1**

**\*\* NOTE:** Save all packing materials and take care not to tear cartons. Remove all hardware and misc. parts. Check parts / hardware list and confirm all parts necessary hardware are included before installation. It's a good idea to spray all OE attaching hardware with penetrating oil before beginning removal of OE bumper(s). This will ease removal as well as help assure that none of the bolts/nuts' threads are damaged during removal.

### Step 1

Remove OE spare-tire mount, lower bump-stop and 3rd brake light, if equipped from tailgate. ON TJ and YJ models the upper bump-stops remain installed. Save all OE attaching hardware. A 3rd brake light extension bracket (PN TJ-5120 or JK-5120) is available should you want to re-install. All are available from your Body Armor dealer.  
See photos on last page for reference.

### Step 2

Next attach the Swing-A-Way. Place the Swing-A-Way arm into position and drop in the hinge-pin. Rotate the pin so the notch aligns to the set-screw, and tighten the set-screw into the collar of the hinge-tower. The notch and set-screw must be aligned properly to prohibit hinge-pin movement, keeping hinge-pin from spinning up and out of tower.

### Step 3

OE bumper mounting bracket bolts can be placed back in frame and tightened to keep threads free of debris and moisture. See Photos 4 and 6 on last page for reference.

### Step 4

- a. Next, if you purchased one, install Hi-Lift Jack with 1/2" x 2" bolts, flat washers, non-lock hex nuts, and ny-lok nuts, with the foot of the jack to the passenger side.
  - b. Install spare mount into upper receiver tube on Swing-A-Way with 1/2" x 4" bolt with (2) moon washers and ny-lok nut. Adjust to depth desired / needed for spare tire / wheel clearance.
  - c. Check condition of the upper rubber bump-stops on tailgate as they will be a resting support for Swing-A-Way arm.
  - d. Adjust Swing-A-Way latch (as needed) for minimal amount of torq needed for latching. Do not over adjust as too much tension will not allow latch to close properly without damaging "u-bolt" and / or latch-plate attaching bolts in bumper face.
  - e. Install set-bolt (1/2" x 1") into bottom of tire / wheel receiver tube to prevent rattling / movement of spare tire mount assembly.
  - f. If you purchased a 3rd brake light extension bracket, install it now per instructions.
- See photos on last page for references on all of above steps.

We recommend you check the torque of all bolts after about two weeks, and after every off-road / trail run to assure tightness.

1. MOUNT BASE REAR BUMPER FIRST.
2. ATTACH SWING-A-WAY SECOND.

**'05-'06 TJ Owners please see note on hardware page before beginning installation.**

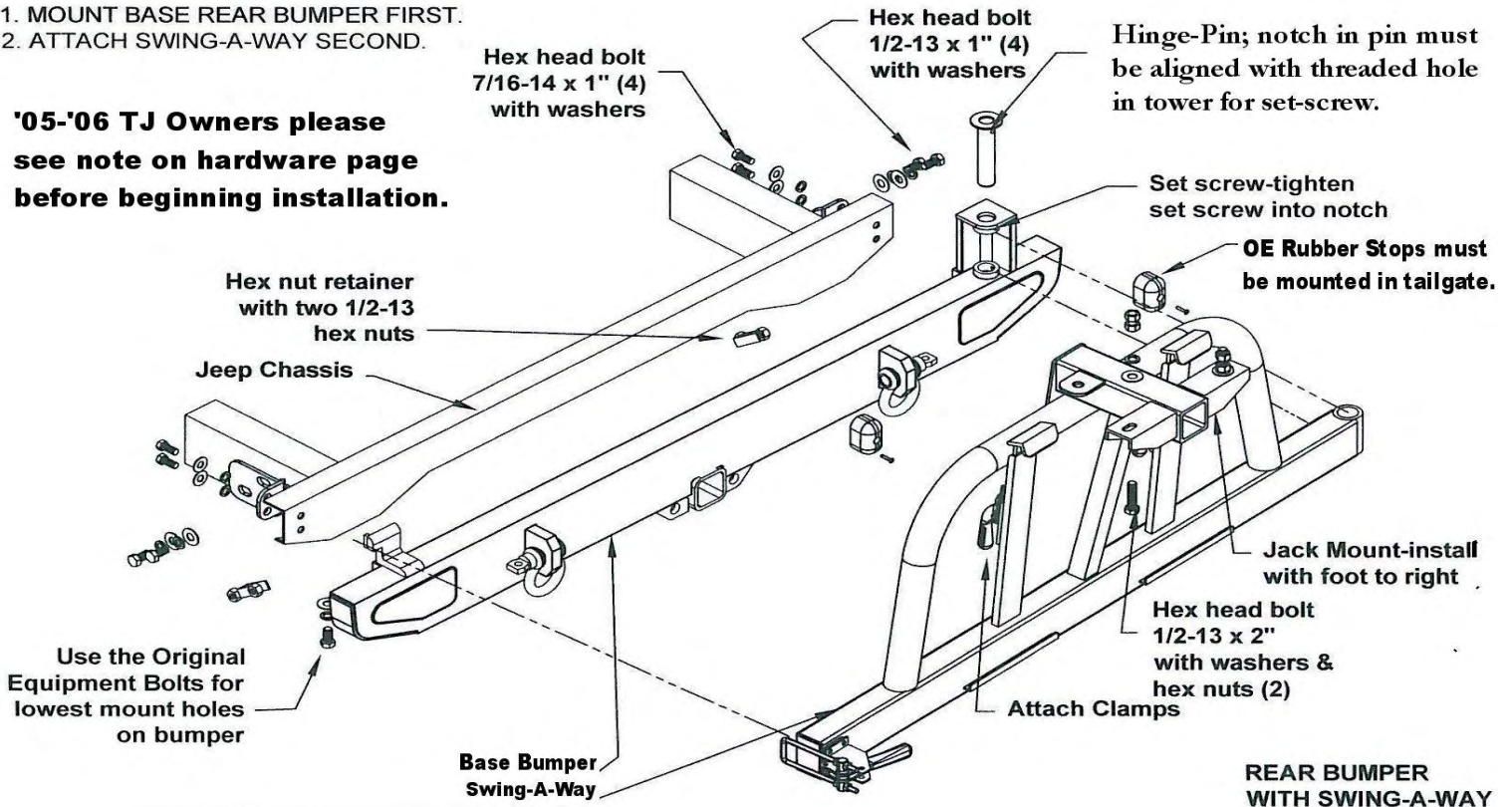

\* = Includes Unlimited

Check out our website for the latest in Body Armor gear, tech bulletins, and our new vehicle photo gallery.

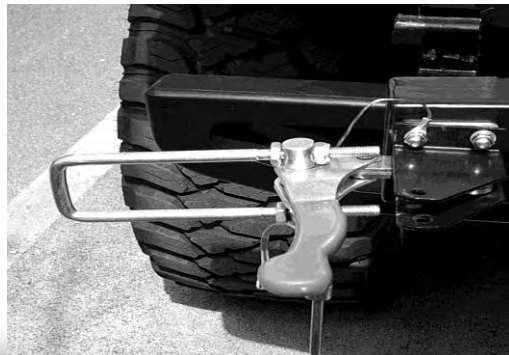
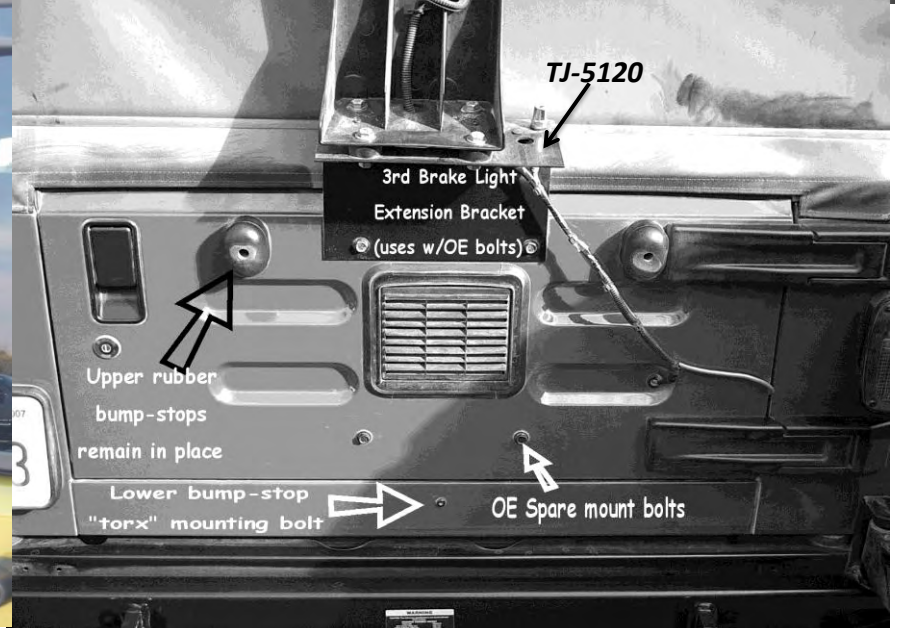
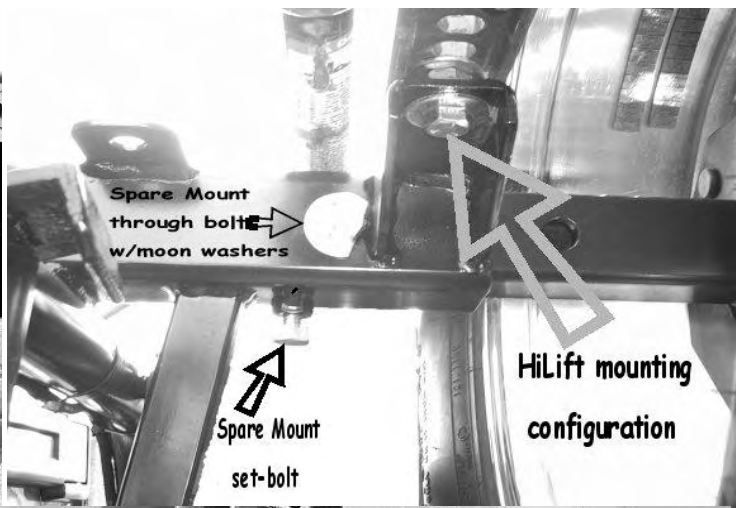
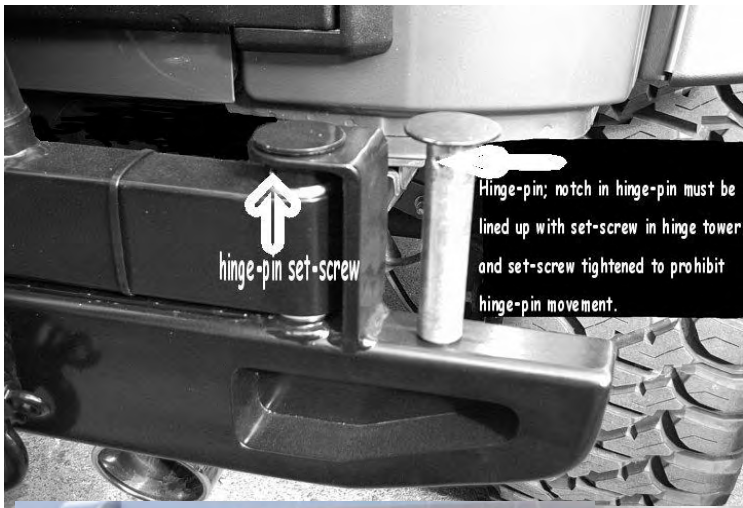

Latch and latch-plate  
Adjust latching "U-bolt" so it takes no more than 25lbs to latch handle and remain closed. More than this amount of torque to latch could result in damage to the "U-bolt" and / or latch-plate and bolts over time.

