

# BODY ARMOR

BY TOLAR MFG. CO., INC.

## TOYOTA FJ CRUISER - FRONT BUMPER INSTALLATION INSTRUCTIONS



treme trailgear  
for the serious  
offroader!

[www.bodyarmor4x4.com](http://www.bodyarmor4x4.com)

## Hardware Kit - TOYOTA FJ CRUISER

### **DO NOT INSTALL THIS PRODUCT ON ANY VEHICLE OTHER THAN TOYOTA FJ CRUISER**

Body Armor designed this product to give you years of dependability and performance. If you encounter any problems during installation of this product, or at any later date, please contact your authorized Body Armor dealer, or call 951-808-0750 for our customer service department, or check our website for tech bulletins regarding your year and model vehicle. Our hours are Monday thru Thursday 7AM-4:30PM and Friday 8AM-12PM, Pacific Time.

#### **Suggested tools for installation;**

3/8" ratchet with 6" to 8" handle (or 1/2" ratchet with 3/8" adaptor)  
Metric sockets from 8mm to 19mm  
Assorted hand-wrenches (metric and U.S.)  
Straight and phillips screwdrivers  
Voltmeter/test light (for optional PIAA 004XT driving light installation)  
Masking tape (light adhesive painters' tape preferable)

Installation time will vary with experience. Estimated bumper install is 2.5 to 3 hours. With lights and/or winch, time will be double or more.

It is recommended to have a helper in the removal of your OE bumper and installation of your new Body Armor bumper. The OE bumper is very light, but care needs to be taken to prevent damage to your FJ's fascia and/or grill during removal. Your new Body Armor bumper, though not overly heavy in comparison to other aftermarket bumpers, can be awkward to guide onto frame-caps and hold up during installation (especially with a winch). No modifications to any factory components need or should be made to install your Body Armor FJ Bumper. Air-bag sensors and A/C line are not affected, and if so equipped, the OE chassis skid plate bolts into the factory location.

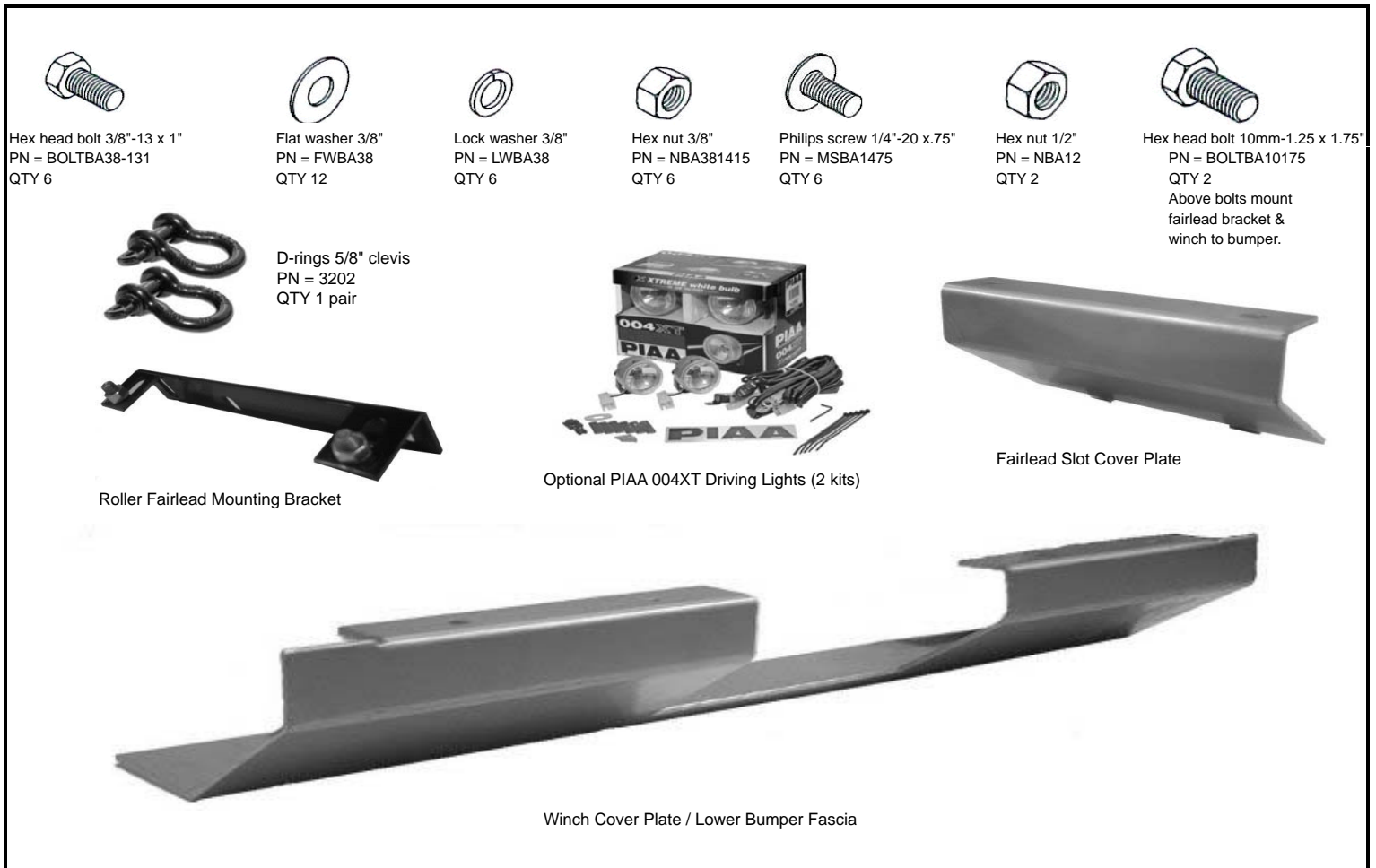

**Important: Before beginning installation, assure that all parts and hardware listed for your FJ bumper are contained in this package. Please contact us immediately should there be any shortages in parts and/or hardware, or you have questions.**

Check out our website for the latest in Body Armor gear, tech bulletins, and our new vehicle photo gallery.

## Front Bumper Installation - TOYOTA FJ CRUISER

### Step 1 **Very Important**

Before beginning installation, assure that vehicle has been pulled forward into work-area with the wheels straight and that the ground is level. The clearances around the FJ bumper are critical to proper installation and fitment. Moving vehicle with wheels turned causes slight frame twist preventing ease of removal of OE bumper and installation of new bumper without issue. Make sure you have plenty of room to work around front of vehicle. Open the hood at this time, you will need to see down through the inner-body core-support while removing your OE bumper and installing your Body Armor FJ Bumper.

### Step 2

- Unpack bumper using staple puller to remove staples. Save all packing materials and take care not to tear cartons.
- Remove hardware and misc.parts. Check parts/hardware list to confirm all parts and necessary hardware are included.
- It's a good idea to spray all OE attaching hardware at this time with penetrating oil before beginning removal of OE bumper. This will ease removal as well as to help assure that none of the bolts' / nuts' threads are damaged during removal. Use extra caution when working with the bumper mounting studs & nuts.

### Step 3

- Begin removing OE bumper following instructions and photos on the following page for detailed descriptions and references. When done, proceed to Step 4 here.

### Step 4

- If equipped, remove OE chassis skid plate and set aside for install after new bumper is installed. Save OE hardware to re-install the skid plate once new bumper is installed (3 upper bolts and 2 lower bolts, lowers have spacers between frame & skid plate).
- Remove the (3) outer hold-down hex nuts holding bumper to frame-caps on both passenger and driver sides. Un-clip the outer ends of the bumper from the outer bumper support clips (see Photo 5 on following page) by pulling bumper fascia down and out of clip on driver and passenger sides. Next, while a helper holds the bumper in place, loosen and remove the inner hold-down hex nuts on both passenger and driver sides. Reference Photo 1 on the last page for stud locations. The bumper should now slide off the front of the locating / mounting studs in the frame-caps. Remove slowly prevent paint damage. Save hold-down nuts.
- Remove the outer bumper support clips from both driver and passenger sides (see Photo 5 on following page)

### Step 5

- If you bought a winch, skip to Step 5b. If you did not purchase a winch, you can mount the winch cover plate / lower bumper fascia, and fairlead slot cover plate to the bumper now, using (6) 3/8" x 1" bolts with (2) flat washers, (1) lock washer, and (1) hex nut on each bolt. See photos 4 & 5 on the last page for reference.
- If you purchased a winch for your FJ, now is the time to mount it in the bumper. The winch will bolt down using the fairlead mounting bracket and 10mm bolts to secure winch & fairlead bracket to bumper. The roller fairlead bolts to the fairlead bracket using the 1/2" hex nuts supplied. See photo 3 on the last page for reference. Be sure to mount with the correct side of winch to passenger side for solenoid pack installation / clearance. Once the winch is bolted in, you can mount the winch cover plate / lower bumper fascia to the bottom of the bumper using (4) of the 3/8" x 1" bolts with (2) flat washers, (1) lock washer and (1) hex nut on each bolt. If you purchased your FJ bumper with PIAA lights, mount them as shown in photo 2 on the last page.

**Important:** Follow winch mfr's directions for cable to winch / solenoid / battery connections. Use caution to assure clearance of any and all bumper / winch / mounting surfaces at all cable end connections. Coil cables and lay in winch mount plate to protect against damage while installing bumper onto vehicle. Place coiled cables in winch mount plate to assure no interference with the radiator, a/c line and / or inner body core support during bumper installation. Cables to be run in Step 7.

### Step 6

Along with your helper, one person on each side, guide your Body Armor FJ Bumper onto the the frame-cap mounting studs. Use caution guiding the bumper on slowly and evenly to prevent paint damage. Locating / mounting studs and bumper mounting plates can be seen down through inner-body core support while guiding bumper into place. Make sure the bumper does not contact grill or fascia while installing bumper as this can cause paint damage. While you or your helper hold the bumper in place, thread the OE hold-down nuts onto mounting studs to hold the bumper in place, hand tighten at this time.

### Step 7

Confirm bumper is even side-to-side, torque hold-down nuts to 80 ft.lbs. Again confirm bumper is even and there are no clearance issues between the bumper and any part of the body and / or inner-body core-support. You can now run the winch cables through the inner-body core support to the battery. If you purchased your FJ bumper with PIAA lights, you can now wire these up following PIAA's detailed instructions with each light kit.

### Step 8

- Fit the wheel well inner-liner end-caps to the bottom of the bumper at each corner and bolt up with supplied 1/4" x .75" phillips-head machine screws, (2) each side, into drilled / threaded holes in bottom corners of bumper. See photos 6 & 7 on the last page.
- Next, using the OE hardware and spacers, re-install your chassis skidplate, making sure it's straight before tightening.
- Using the (2) remaining 1/4" x .75" phillips-head machine screws, mount your license plate to threaded holes in the bumper face.
- Re-install the grill by snapping onto clips and using the OE push-pins and screws to hold down in OE locations.

We recommend you check the torque of all bolts after about two weeks, and after every off-road / trail run thereafter to assure tightness.

Check out our website for the latest in Body Armor gear, tech bulletins, and our new vehicle photo gallery.



Photo 1 - Remove the "push-pins" from grill mounts outside of headlights. Remove the hold-down screws at the top inner edge of grill (all circled in white above). Remove the grill by popping the snap-clips (2 on each side just inside the headlights) and pull forward off your FJ.



Photo 2 - Unclip bumper fascia from fascia support bracket through removed grill opening.



Photo 3 - Inner wheel-well attaching bolts and end cap attaching bolts (located under bumper) Do not remove inner wheel wells, let hang.



Photo 4 - Bumper "fascia" support bracket and outer support clips

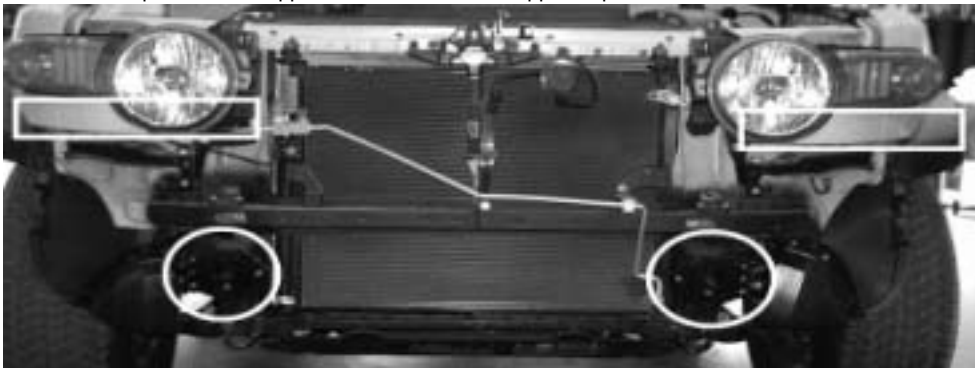

Photo 5 - Bumper locating / attaching studs (circled) and mask-off areas on body (h



Photo 5 - Outer bumper support clips. These must be removed from both sides.

Photo 1 - Removing grill. Grill is attached with (2) push-pins, (2) screws, and (4) snap-clips (2 snap-clips per side).

Photo 2 - Removing bumper "fascia" support bracket. Bumper fascia is fastened to the support bracket by "push-pins". Remove the push-pins attaching bracket to bumper, then remove the (3) screws circled in Photo 2 and remove the fascia support bracket.

Photo 3 - Detaching the inner wheel-wells and end caps. (2) bolts into back of bumper each side, and (3) to the bottom each side.

Photo 4 - Bumper "fascia" support bracket and outer bumper support clips. Reference for identification of pieces.

Photo 5 - Outer bumper support clips' locations on your FJ. These must be removed from each side for proper fitment of your new bumper.

Photo 6 - Mask-off the highlighted areas (rectangles) before moving on to Step 4 on the previous page. Use a light-stick masking tape to mask off above bumper line and around headlights / turn signals to prevent paint damage in the event of bumper slippage during removal of the OE bumper and installation of your Body Armor bumper. Masked areas include lower portion of grill and fascia, extending to flares.

Check out our website for the latest in Body Armor gear, tech bulletins, and our new vehicle photo gallery.

