



**BUMPER INSTALLATION INSTRUCTIONS - FRONT BUMPER
2007- Current JEEP WRANGLER JK - all models**



www.bodyarmor4x4.com

Hardware Kits - JK, JK Rubicon, JK Rubicon Unlimited

DO NOT INSTALL THIS PRODUCT ON ANY VEHICLE OTHER THAN JEEP JK* MODELS.

Body Armor designed this product to give you years of dependability and performance. If you encounter any problems during installation of this product, or at any later date, please contact your authorized Body Armor dealer, or call 951-808-0750 for our customer service department, or check our website for tech bulletins regarding your year and model vehicle. Our hours are Monday thru Thursday 7AM-4:30PM and Friday 8AM-12PM, Pacific Time.

Important: Before beginning installation, assure that all parts and hardware listed for your specific bumper are contained in this package. Please contact us immediately should there be any shortages in parts and/or hardware.



1 pair "D"-rings included with every front and rear bumper, and every rear bumper with Swing-A-Way (also available separately)
Part # 3202 = (1) pair

Front Bumper - JK*



Hex Nut 1/2"
PN=NBA12
QTY 6



Flat Washer 1/2"
PN=FWBA12
QTY 6



Lock Washer 1/2"
PN=LWBA12
QTY 6



Hex Nut 3/8"
PN=NBA38
QTY 2



Flat Washer 3/8"
PN=FWBA38
QTY 2



Lock Washer 3/8"
PN=LWBA38
QTY 2

Accessories also available separately to accent and / or outfit your Body Armor Bumpers - inquire with your Body Armor Dealer.



JK-5123 Front Skid Plate



JK-6124 Roof rack and 5124 Cargo Basket



Towbar Adaptor Brackets
Part # 3200 - vertical pin
Sold Separately (per pair)



Towbar Adaptor Brackets
Part # 3210 - horizontal pin
Sold Separately (per pair)



License Plate Bracket
Part # 5121
Sold Separately



JK-6124 and 5124 cargo system shown with Body Armor Trail Doors PN JK-6135 & JK-6136

* = Includes Unlimited

Front Bumper Installation - Jeep JK*

Step 1

Unpack bumper using staple puller to remove staples. Save all packing materials and take care not to tear cartons. Remove all hardware and parts. Check parts / hardware list and confirm all parts and necessary hardware are included before installation. It's a good idea to spray all OE attaching hardware with penetrating oil before beginning removal of OE bumper(s). This will ease removal as well as help assure that none of the bolts' / nuts' threads are damaged during removal.

Step 2

- Remove the (2) push-pin screws to remove the plastic frame cover-plate. This can be re-installed if you did not purchase a winch mount plate, though it will either be under the winch plate mounting flanges, or elevated above the frame-rails. Also, the mounting holes in the cover-plate will need to be slotted to bolt to the top of bumper flanges. See Photo 1 on last page for reference.
- Disconnect the OE driving lights at the back of the light housings. Insulate ends and tie the wires to the frame. Do not cut ends.
- Using appropriate tools, remove the OE front bumper by removing the hex nuts holding the bumper to frame mount flanges. See diagram below for reference. Installation kit contains all new necessary attaching hardware for your Body Armor JK Bumper.
- If you did not purchase a winch plate and winch, re-install the plastic frame cover-plate to frame rails if plate mounting flanges showing is desired. Our bumper was designed for use with a winch mount plate and winch, no cover-plate option is available.

Step 3

Slide your new Body Armor JK bumper's mounting studs into the locating holes in the frame mounting flanges and hand tighten one hex nut onto a stud on each side. Assured that bumper is straight, install remaining hex nuts and torque down evenly starting with the top studs. These studs are threaded into and tack-welded to bumper mounting / backing plates. Do not weld or over-torque the studs. Your new Body Armor bumper is designed as a no-weld, bolt-on application and should be installed as such.

Step 4

- Install either our winch mount plate (see photos on last page for reference) per instructions, or the OE plastic frame cover-plate if bolting to the top and covering the winch plate mounting flanges is desired. No cover-plate option is available.
- If you purchased lights for your JK Bumper, install per mfrs' directions at this time. If using the OE driving light wiring harness, refer to Jeep specs or inquire with Jeep as to the capacity of OE wiring and routing.

We recommend you check the torque of all bolts after about two weeks, and after every off-road / trail run to assure tightness.

Below diagram reflects part # JK-19431, "Quad Hoop Bumper" - Part # JK-19331, "Triple Hoop Bumper" mounts the same as described.

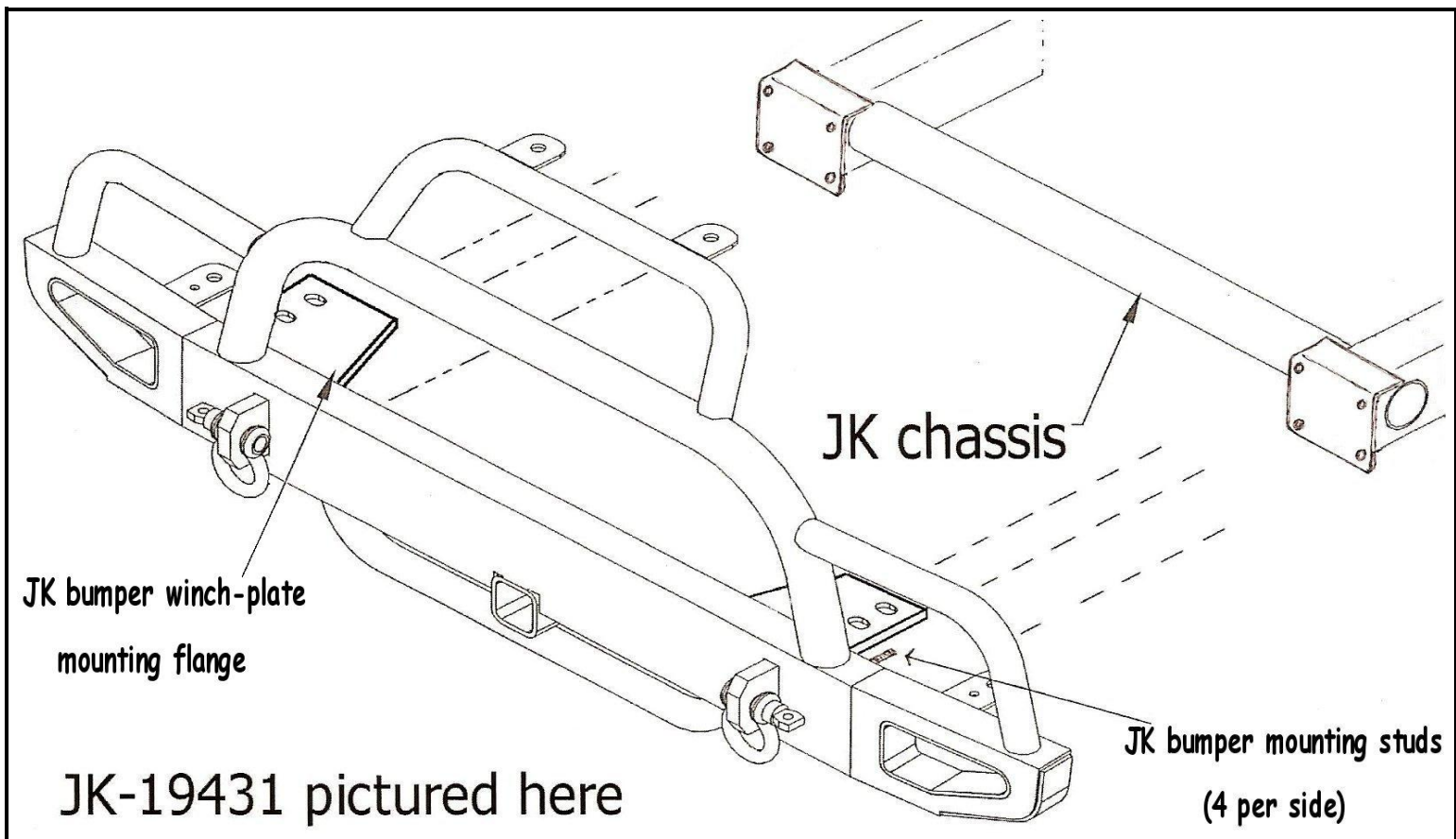

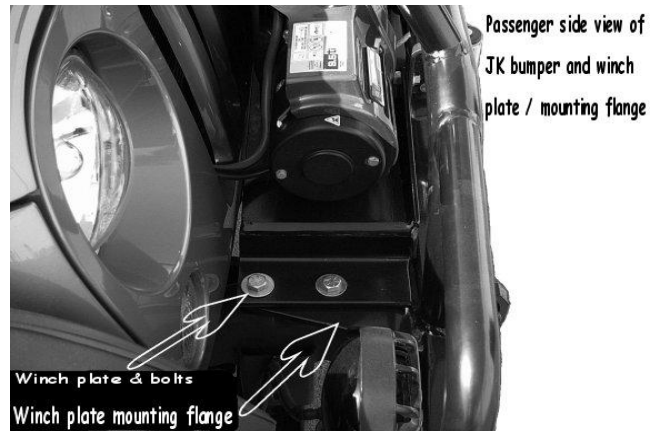

Passenger side view of JK bumper and winch plate / mounting flange

Winch plate & bolts
Winch plate mounting flange

Photo 2 - passenger top-view winch plate mounting.

Photo 1 - OE bumpers and front frame cover-plate.

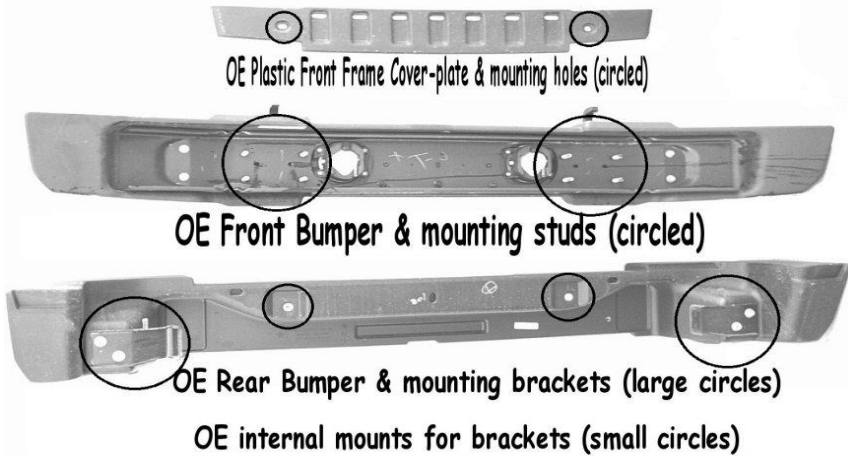

OE Plastic Front Frame Cover-plate & mounting holes (circled)

OE Front Bumper & mounting studs (circled)

OE Rear Bumper & mounting brackets (large circles)

OE internal mounts for brackets (small circles)

Photo 3 - Front bumper mounting flange & studs - Winch plate mounting.

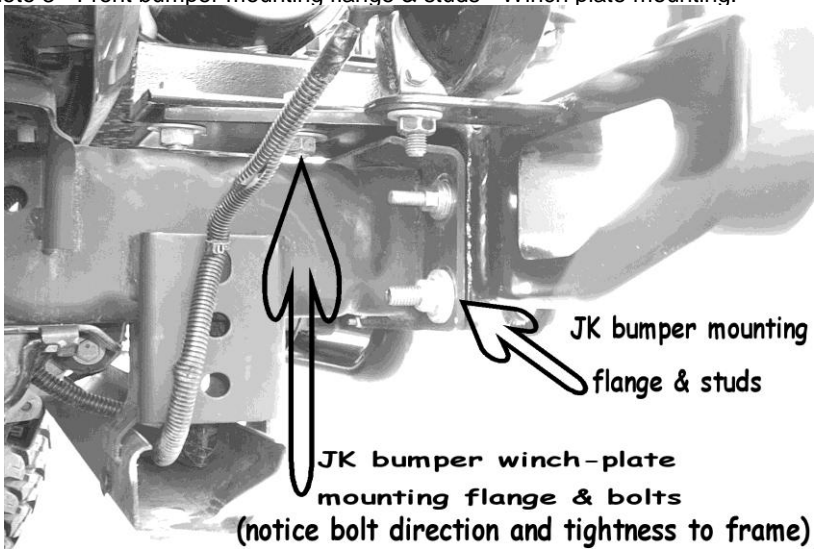

JK bumper mounting flange & studs

JK bumper winch-plate mounting flange & bolts
(notice bolt direction and tightness to frame)