

# BODY ARMOR

BY TOLAR MFG. CO., INC.

BUMPER INSTALLATION INSTRUCTIONS - FRONT BUMPER - REAR BUMPER - REAR BUMPER WITH SWING-A-WAY

JEEP WRANGLER TJ (1997 TO 2006) - all models including X, SE, SPORT, RUBICON, RUBICON UNLIMITED



treme trailgear  
for the serious  
offroader!

[www.bodyarmor4x4.com](http://www.bodyarmor4x4.com)



## Hardware Kits - TJ, Rubicon, Rubicon Unlimited

**DO NOT INSTALL THIS PRODUCT ON ANY VEHICLE OTHER THAN JEEP TJ\* MODELS.**

Body Armor designed this product to give you years of dependability and performance. If you encounter any problems during installation of this product, or at any later date, please contact your authorized Body Armor dealer, or call 951-808-0750 for our customer service department, or check our website for tech bulletins regarding your year and model vehicle. Our hours are Monday thru Thursday 7AM-4:30PM and Friday 8AM-12PM, Pacific Time.

**Special Note:** On 2005 and 2006 Jeeps TJ's we have found fitment issues with the rear Swing-A-Way bumper # TJ-2991 and # TJ-2491. The models affected include Rubicon, Sport and Unlimited. Field research has revealed that the Jeep crossmember is indeed the problem, not our bumper. We examined one each of the Rubicon, Sport & Unlimited (all new on the showroom floor) and discovered that the crossmember was cantilevered in at the top by approximately 3 degrees. This tilts the top of the bumper forward the same angle when bolted up and will not allow the swing arm to align and/or close properly. We have been providing 1/8" washers to shim the top of the bumper out from the crossmember, at the top bolts only, to customers upon request. Should you need these washers, please contact us, and we will ship them to you at no charge. These are standard 1/8", 7/16" id sae washers. See photo on last page for reference in placement of washers / spacers.







**Front Bumper - TJ\***

 Hex head bolt 1/2-13 x 1 1/2" PN=BOLTBA12-1311/2 QTY 6	 Lock washer 1/2" PN=LWBA12 QTY 6	 Flat washer 1/2" PN=FWBA12 QTY 6
---	---	---



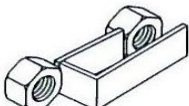







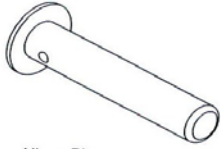

1 pair "D"-rings included with every front and rear bumper, and every rear bumper with Swing-A-Way (also available separately)  
 Part # 3202 = (1) pair

**Rear Base Bumper - TJ\***

 Hex head bolt 7/16-14 x 1" PN=BOLTBA716-141 QTY 4	 Lock washer 7/16" PN=LWBA716 QTY 4	 Flat washer 7/16" PN=FWBA716 QTY 4	 Hex nut retainer PN=00187 QTY 2
 Hex head bolt 1/2-13 x 1" PN=BOLTBA12-131 QTY 4	 Lock washer 1/2" PN=LWBA12 QTY 4	 Flat washer 1/2" PN=FWBA12 QTY 4	

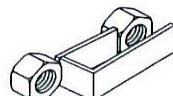
**Rear Bumper with Swing-A-Way - TJ\***

 Hex head bolt 7/16-14 x 1" PN=BOLTBA716-141 QTY 4	 Lock washer 7/16" PN=LWBA716 QTY 4	 Flat washer 7/16" PN=FWBA716 QTY 4	 Moon washer 1/2" PN = MWBA12 QTY 2	 Hex lock nut 1/2" PN = HLNBA12 QTY 3	 Hinge Pin PN=00171 QTY 1
 Hex head bolt 1/2-13 x 1" PN=BOLTBA12-131 QTY 4	 Lock washer 1/2" PN=LWBA12 QTY 4	 Flat washer 1/2" PN=FWBA12 QTY 12	 Hex nut retainer PN=00187 QTY 2	 Hex nut 1/2" (non-lock) PN = HNBA12 QTY 2	 Hex head bolt 1/2-13 x 4" PN=BOLTBA12-134 QTY 1

**Below support brackets included in both "Base Rear Bumper" and "Swing-A-Way Bumper"**

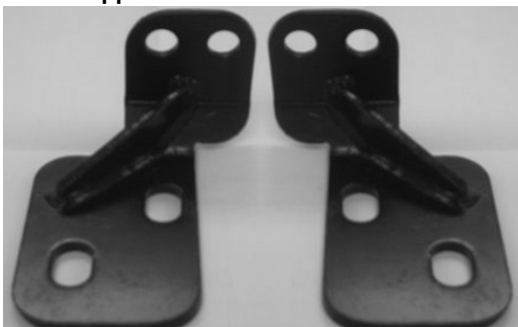

  
 Hex head bolt 1/2-13 x 2"  
 PN=BOLTBA12-132  
 QTY 2

**Important:** Before beginning installation, assure that all parts and hardware listed for your specific bumper are contained in this package. Please contact us immediately should there be any shortages in parts and/or hardware.

\* = Includes Unlimited

## Front Bumper Installation - Jeep TJ\*

### Step 1

- Unpack bumper using staple puller to remove staples. Save all packing materials and take care not to tear cartons.
- Remove hardware and misc. parts. Check parts/hardware list & confirm all parts and necessary hardware are included.
- It's a good idea to spray all OE attaching hardware with penetrating oil before beginning removal of OE bumper(s). This will ease removal as well as help assure that none of the bolts/nuts' threads are damaged during removal.

### Step 2

Using appropriate tools, remove the OE front bumper, as well as lights, tow-hooks, etc., saving all OE hardware. Our installation kit contains new grade 5 bolts with necessary attaching hardware. These should be used if OE bolts/hardware are not desired.

### Step 3

Slide your new Body Armor bumper in place of the OE bumper onto the frame at the OE mounting location. If you purchased a Body Armor winch plate, check fitment at this time before installing either our grade 5 bolts, or your OE bolts/hardware. Hand tighten all bolts before torquing with ratchet, air-impact, etc. Your new Body Armor bumper was designed as a no-drill, bolt-on application and should be installed as such.

### Step 4

Confirm that bumper is even side-to-side, as well as front-to-back (take measurements from outside of frame-rail to ends of bumper, and from an equal point on frame or body to the back of bumper on each side). Assured bumper is straight, now torque bolts evenly starting with the bottom bolts. Recheck that bumper is even and re-torque accordingly.

We recommend you check the torque of all bolts after about two weeks, and after every off-road / trail run thereafter to assure tightness.

Below diagram reflects part # TJ-19431, "Quad Hoop Bumper" - all "Base", "Center", "Twin" and "Triple Hoop" bumpers mount the same.

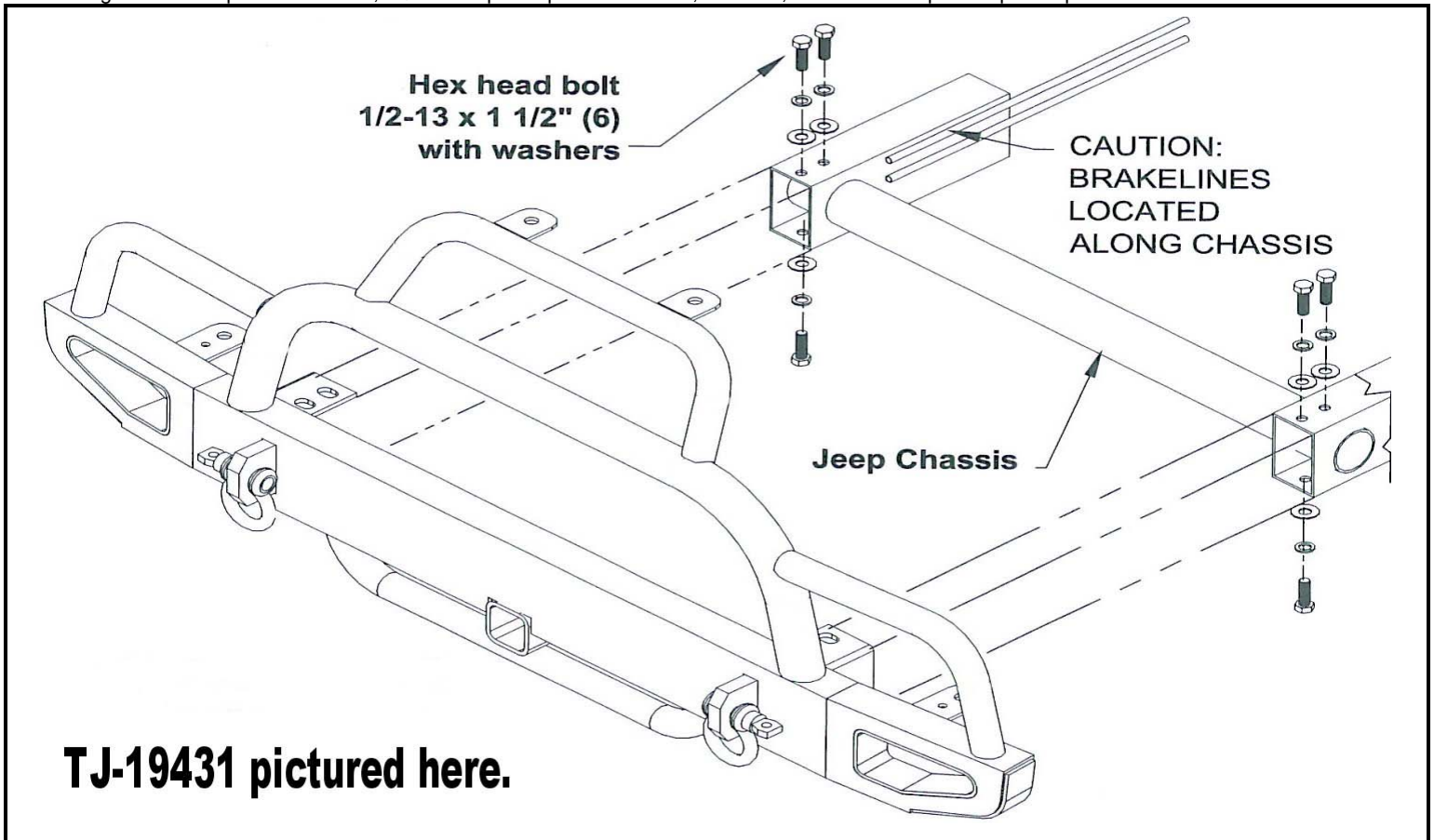

Towbar Adaptor Brackets  
Sold Separately  
Part # 3200 - vertical pin

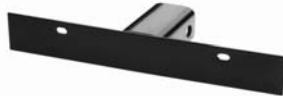

License Plate Bracket  
Sold Separately  
Part # 5121



Towbar Adaptor Brackets  
Sold Separately  
Part # 3210 - horizontal pin

\* = Includes Unlimited

## Rear Bumper Installation - Jeep TJ\*

### Step 1

- Unpack bumper using staple puller to remove staples. Save all packing materials and take care not to tear cartons.
- Remove hardware and misc.parts. Check parts / hardware list & confirm all parts and necessary hardware are included.
- It's a good idea to spray all OE attaching hardware with penetrating oil before beginning removal of OE bumper(s). This will ease removal as well as help assure that none of the bolts/nuts' threads are damaged during removal.

Note: 05-'06 TJ owners please see note regarding rear crossmember on hardware page before beginning installation of new bumper.

### Step 2

Using appropriate tools, remove the OE rear bumper, as well as lights, tow-hooks, etc., saving the (2) lowest mounting bolts. Our installation kit contains new grade 5 bolts with necessary attaching hardware. These should all be used in place of OE bolts and / or hardware except for the lowest bolt on each side (should OE bolts be desired).

### Step 3

Bolt the support brackets to the frame rails using the "hex-nut retainers", making sure holes in rear crossmember are lined up with holes in the brackets. To install "hex-nut retainers", insert retainers into the holes in the bottom of the frame-rails and hold by inserting a finger between the clips while threading the 1/2" x 1" bolts with lock-washer and flat washer through bracket and frame into retainer (see photos on last page for reference). Hand tighten only at this time.

### Step 4

Using a floor jack or a helper, hold the bumper in place while threading the 7/16" x 1" bolts with lock-washer and flat-washer through the bracket and frame-rail into the threaded backing plates in bumper. Next install OE bolts through lower tabs into frame. See photos on last page for reference. Hand tighten only at this time.

### Step 5

Confirm that bumper is even side-to-side, as well as front-to-back (take measurements from outside of frame-rail to ends of bumper, and from an equal point on frame or body to the back of bumper on each side). Assured bumper is straight, torque bolts evenly starting with the top bolts into the retainers in side of frame.

We recommend you check the torque of all bolts after about two weeks, and after every off-road / trail run thereafter to assure tightness.

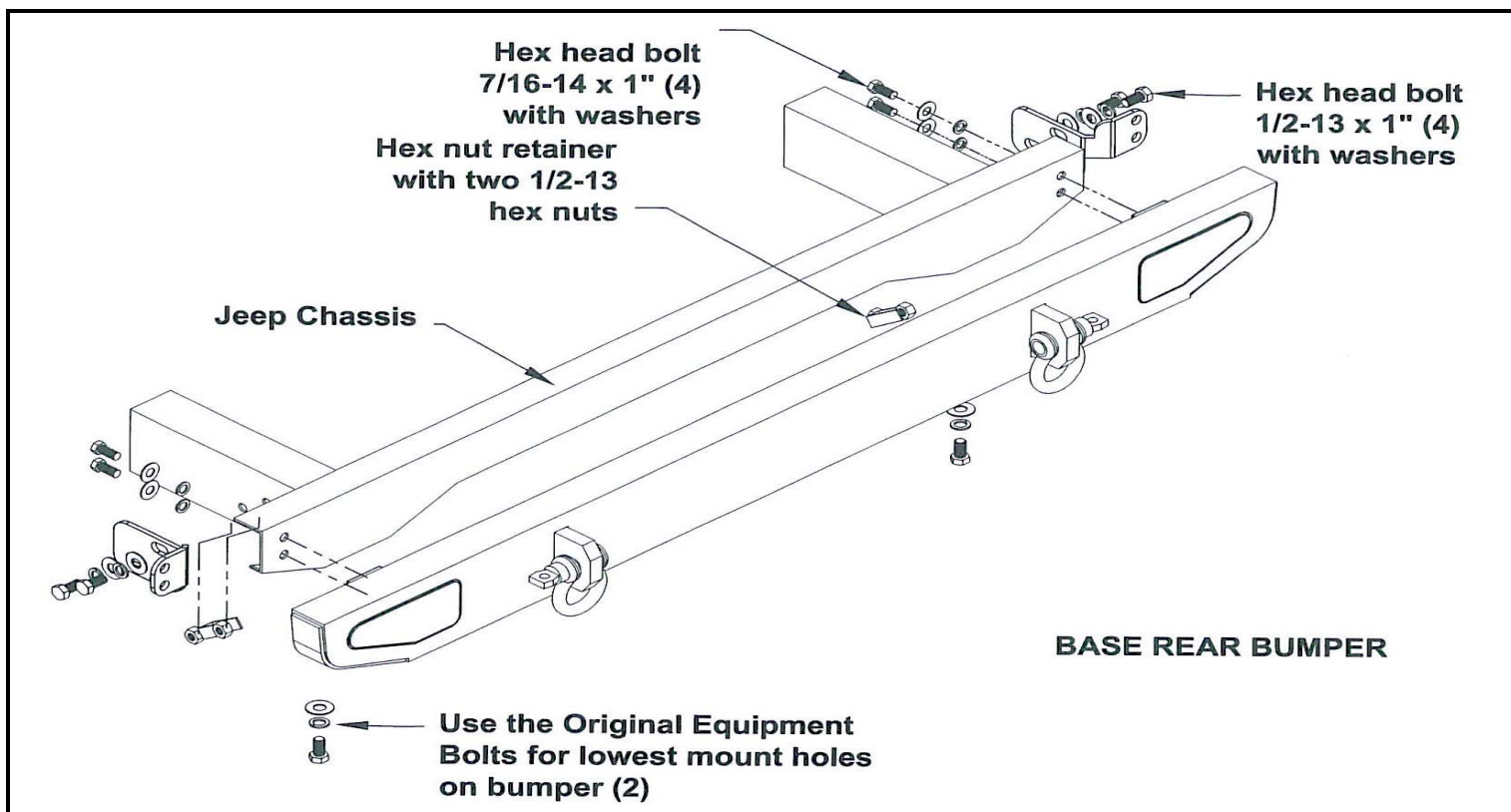

## Rear Bumper with Swing-A-Way Installation - Jeep TJ\*

### Step 1

- Unpack bumper using staple puller to remove staples. Save all packing materials and take care not to tear cartons.
- Remove hardware and misc.parts. Check parts/hardware list to confirm all parts and necessary hardware are included.
- It's a good idea to spray all OE attaching hardware with penetrating oil before beginning removal of OE bumper(s). This will ease removal as well as help assure that none of the bolts/nuts' threads are damaged during removal.

Note: 05-'06 TJ owners please see note regarding rear crossmember on hardware page before beginning installation of new bumper.

Step 2 Repeat Steps 2 through 5 for "Base Bumper", then proceed to Step 3 here.

### Step 3

- Remove OE spare-tire mount, lower bump-stop and 3rd brake light from tailgate. The upper bump-stops remain installed. Save all OE attaching hardware. A 3rd brake light extension bracket is available should you want to re-install. All TJ models use the same extension bracket, part # TJ-5120, available from your Body Armor dealer. See photos on last page for reference.

### Step 4

Next attach the Swing-A-Way. Place the Swing-A-Way arm into position and drop in the hinge-pin. Rotate the pin so the notch aligns to the set-screw, and tighten the set-screw into the collar of the hinge-tower. The notch and set-screw must be aligned properly to prohibit hinge-pin movement, keeping hinge-pin from spinning up and out of tower.

### Step 5

- Next, if you purchased one, install Hi-Lift Jack with 1/2" x 2" bolts, flat washers, non-lock hex nuts, and ny-lok nuts, with the foot of the jack to the passenger side.
- Install spare mount into upper receiver tube on Swing-A-Way with 1/2" x 4" bolt with (2) moon washers and ny-lok nut. Adjust to depth desired / needed for spare tire / wheel clearance.
- Check condition of the upper rubber bump-stops on tailgate as they will be a resting support for Swing-A-Way arm.
- Adjust Swing-A-Way latch (as needed) for minimal amount of torq needed for latching. Do not over adjust as too much tension will not allow latch to close properly without damaging "u-bolt" and / or latch-plate attaching bolts in bumper face.
- Install set-bolt (1/2" x 1") into bottom of tire / wheel receiver tube to prevent rattling / movement of spare tire mount assembly.
- If you purchased a 3rd brake light extension bracket, install it now per instructions. See photos on last page for references on all of above steps.

We recommend you check the torque of all bolts after about two weeks, and after every off-road / trail run thereafter to assure tightness.

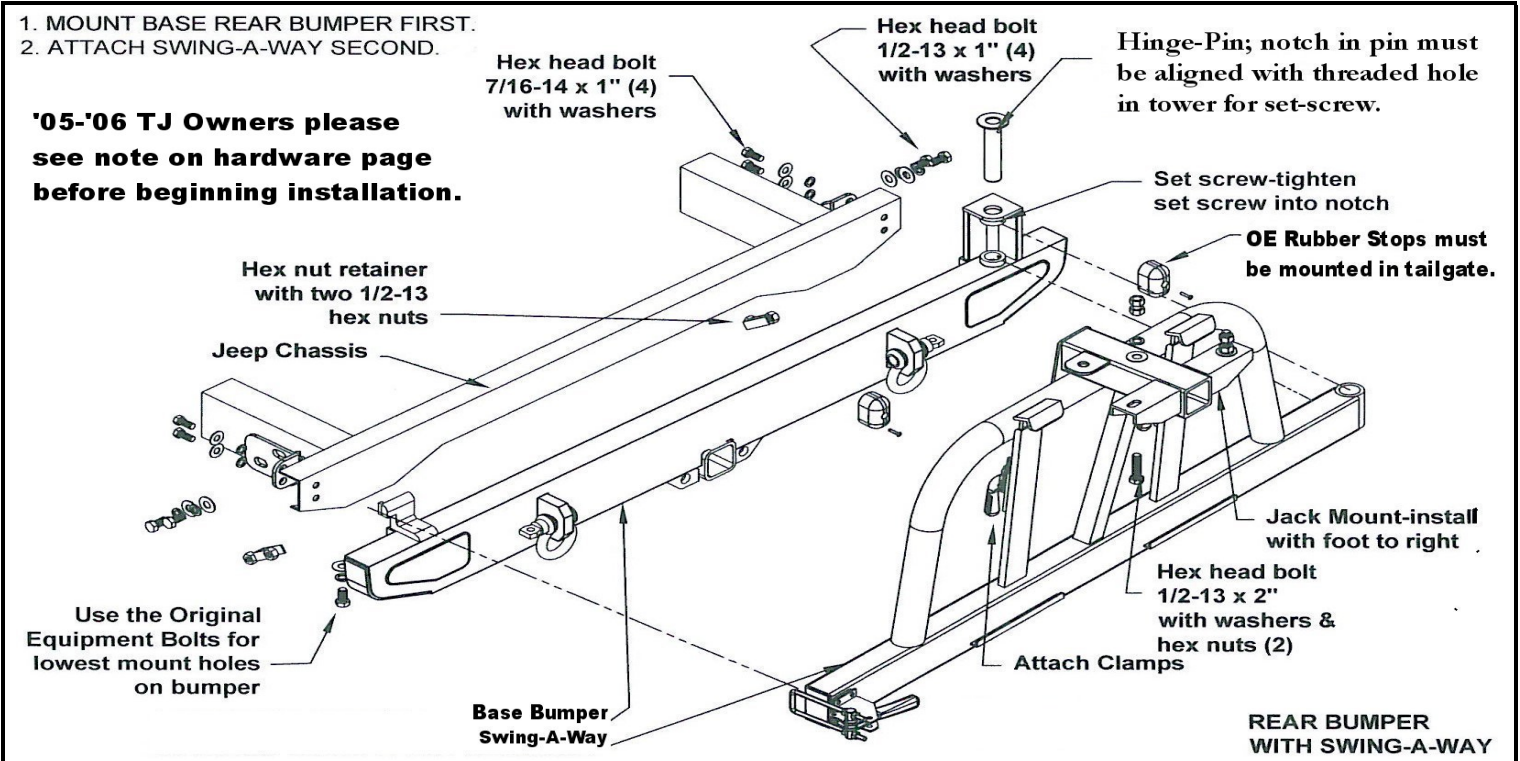

Not affiliated with Daimler-Chrysler

Jeep, Wrangler, Rubicon, Renegade, CJ, Quadra-Trac, Unlimited, and the Jeep grill design are all registered trademarks of Daimler-Chrysler. Tolar Mfg. Inc., Body Armor has no affiliation with Daimler-Chrysler. Throughout any of our printed literature, including catalog(s), these trademark terms are used for identification purposes only. No affiliations are implied or expressed.

\* = Includes Unlimited

Check out our website for the latest in Body Armor gear, tech bulletins, and our new vehicle photo gallery.

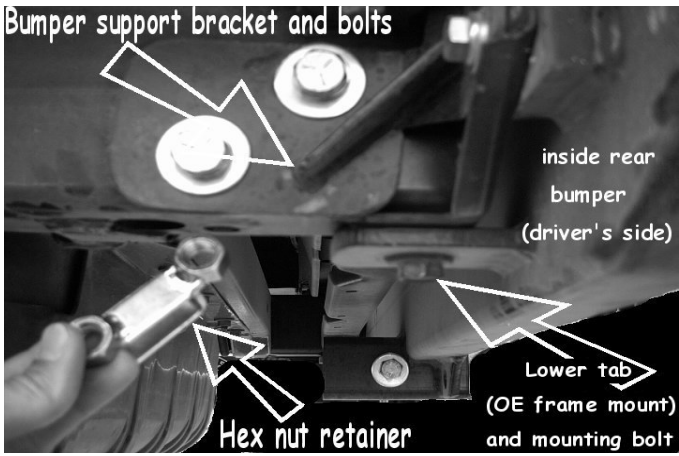

Support brackets - Hex nut retainer - Lower tab at OE frame mount



05-06 TJ owners with canted crossmember - install spacers or washers between crossmember and bumper on upper bolts only.

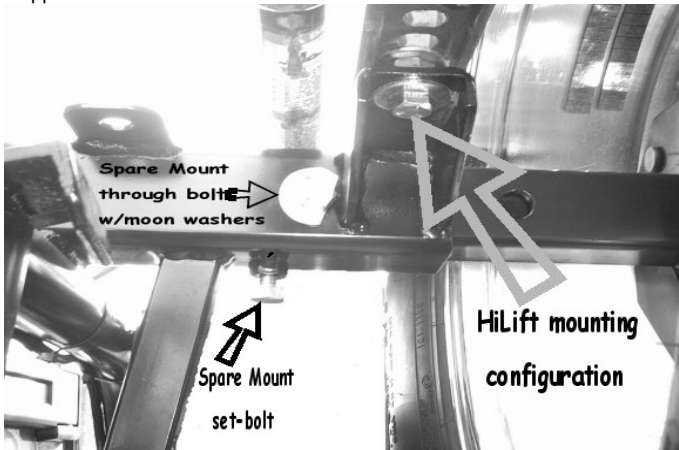

Spare mount - Spare mount set-bolt - Hi-lift jack mounting configuration

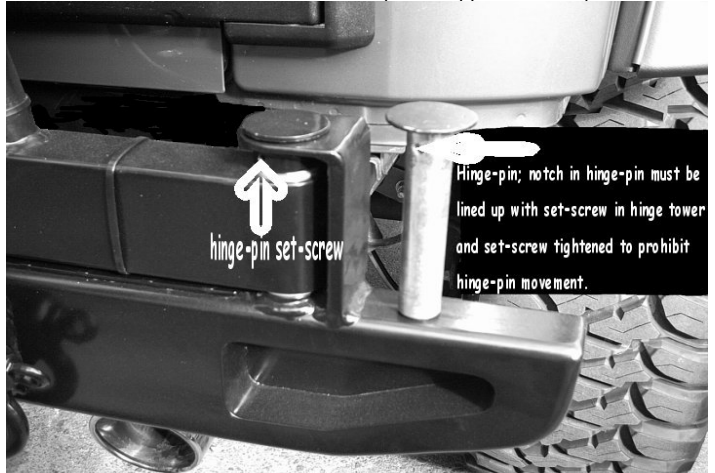

Hinge-pin and tower set-screw

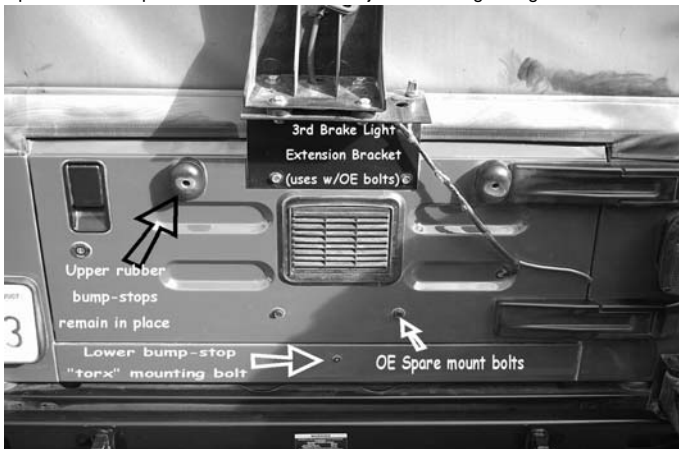

Tailgate - finished view



3rd Brake Light Extension Bracket installed  
Part # TJ-5120  
Sold Separately



Latch and latch-plate  
Adjust latching "U-bolt" so it takes no more than 25lbs to latch handle and remain closed. More than this amount of torque to latch could result in damage to the "U-bolt" and / or latch-plate and bolts over time.



Cooler Rack for B/A Swing-A-Way  
Part # 5122  
Sold Separately  
For up to a 32qt. Cooler



NATO Can Adaptors  
Part # 3201  
Sold Separately



"D"-rings also available separately - Part # 3202



Body Armor Hitch Cap  
Part # 3207  
Sold Separately